

Our HF2 surface is applied using several processes and the quality is controlled by careful inspection during each stage. It is very important to supply a stable quality for safe oiling since the yarn is particularly susceptible to damage at this position. HF2 assists even oiling and reduces oil consumption with its uniformed, rounded peaks holding oil in the oil pools.

Features

- *Compact size allows to attach at the limited space*
-for multi cops winder
-for double oiling system



C612030- 4

YM-99C-HF2

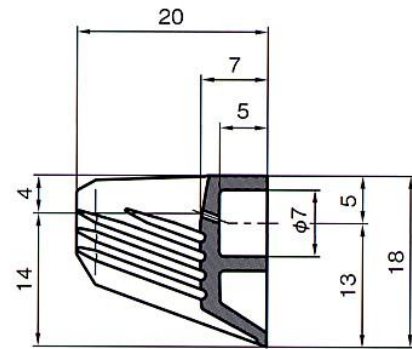

W=1.0

Orifice:Ø0.7 for 10 – 50dtx yarn

C406020- 4

YM-99C-HF2

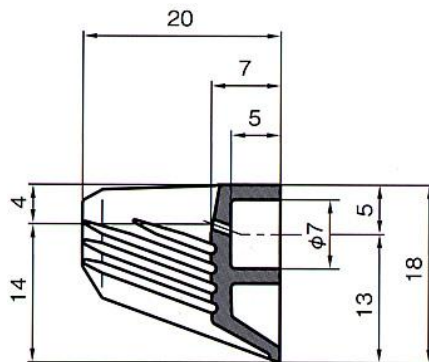

W=1.0

Orifice:Ø1.0 for 50 – 150dtx yarn

C406040- 4

YM-99C-HF2

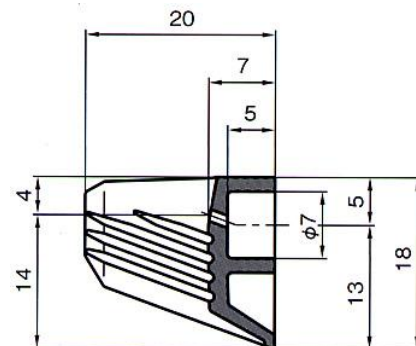

W=1.0

Orifice:Ø1.2 for 50 – 200dtx yarn