

Ring Ring Tensor

ELDON
SPECIALTIES, INC.

PO Box 567 * 821 E. Parker St. Ext.
Graham, NC 27253 * USA
(336) 229-6622 * Fax (336) 229-7180
sales@eldonspecialties.com
www.eldonspecialties.com

Applications;

- For Spandex Yarn as Pre-Tensor
- For Kevlar etc., should not be bent.
- For Spin Dyed Yarn (Top Dyed yarn)
- For Winder
- For Narrow Fabric
- For Creel Tensor
- As Snubber Guides

Features;

- * Various weight ring number is available for your application.
- * Minimize the chattering.
- * Simple maintenance– Pull out/ Push in Rings by hand.
- * Less yarn damage and bent by provide the small tension at each ring.

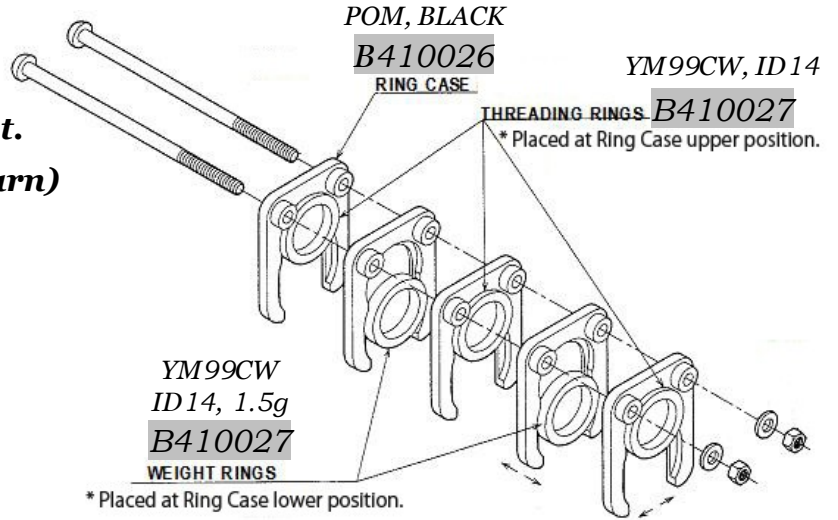

B410025 (6weight type)

* Any Weight Ring Number is available.

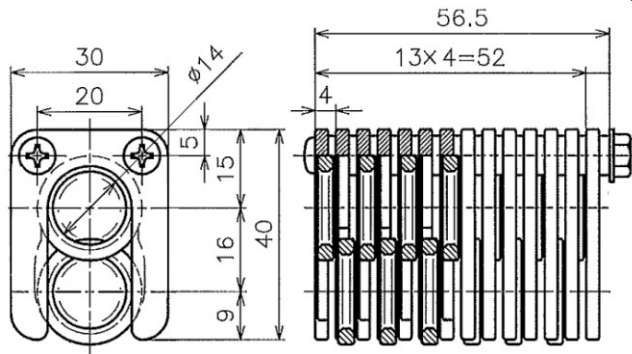

Relations between Numbers of Rings, Yarn Speed and Tension.

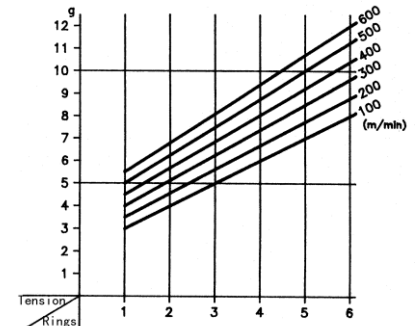

*Fix at 45°reclining makes the tension about 70% of the above value.

With Bracket models – Easy Mounting.

– Able to adjust the tension by fix with the angle.

B803045-A

(3Weight type)

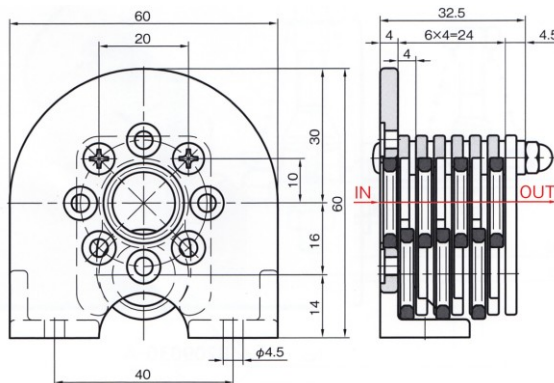

B802045-A

(6Weight type)

