

# Twist Stop Wheel <Metal series>

**ELDON**  
SPECIALTIES, INC.

PO Box 567 \* 821 E. Parker St. Ext.  
Graham, NC 27253 \* USA  
(336) 229-6622 \* Fax (336) 229-7180  
sales@eldonspecialties.com  
www.eldonspecialties.com

## Application

For draw texturing machines

- 1, Able to protect twists back into creels
- 2, Minimize wear on the feed rollers
- 3, Make yarn feeding smoother on starting-up



## Features for metal twist stops

1. Less Yarn Damage - Very Fine Surface Finish with excellent HARD CHROME COATING.
2. Economic pricing.
3. Light Weight and Less Fragile by hitting or dropping.
4. Able to replace Bearing.
5. Two models in DIA30 and DIA32 are available.

### DIA32 <B505005>

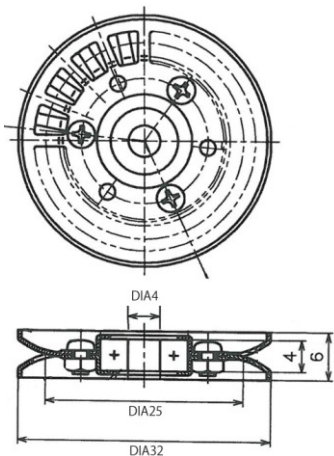

Assembled by  
3screws and 3nuts.

### DIA30 <D301002/D211041>



3screws & 3nuts



3screws & fastener

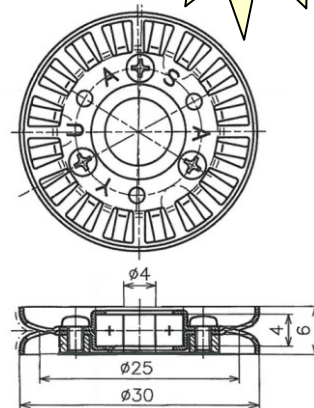

**NEW**

### Assembled models with Holder



Holders for Barmag  
(FK6 & AFK) and Scragg  
(DCS1200) are available.

eg.) Barmag type

B605001-B505005(DIA32)&Holder

D304041-D301002(DIA30)&Holder

### Attachment position

**\*\*Just BEFORE the heater.**

eg.) V shape heater

